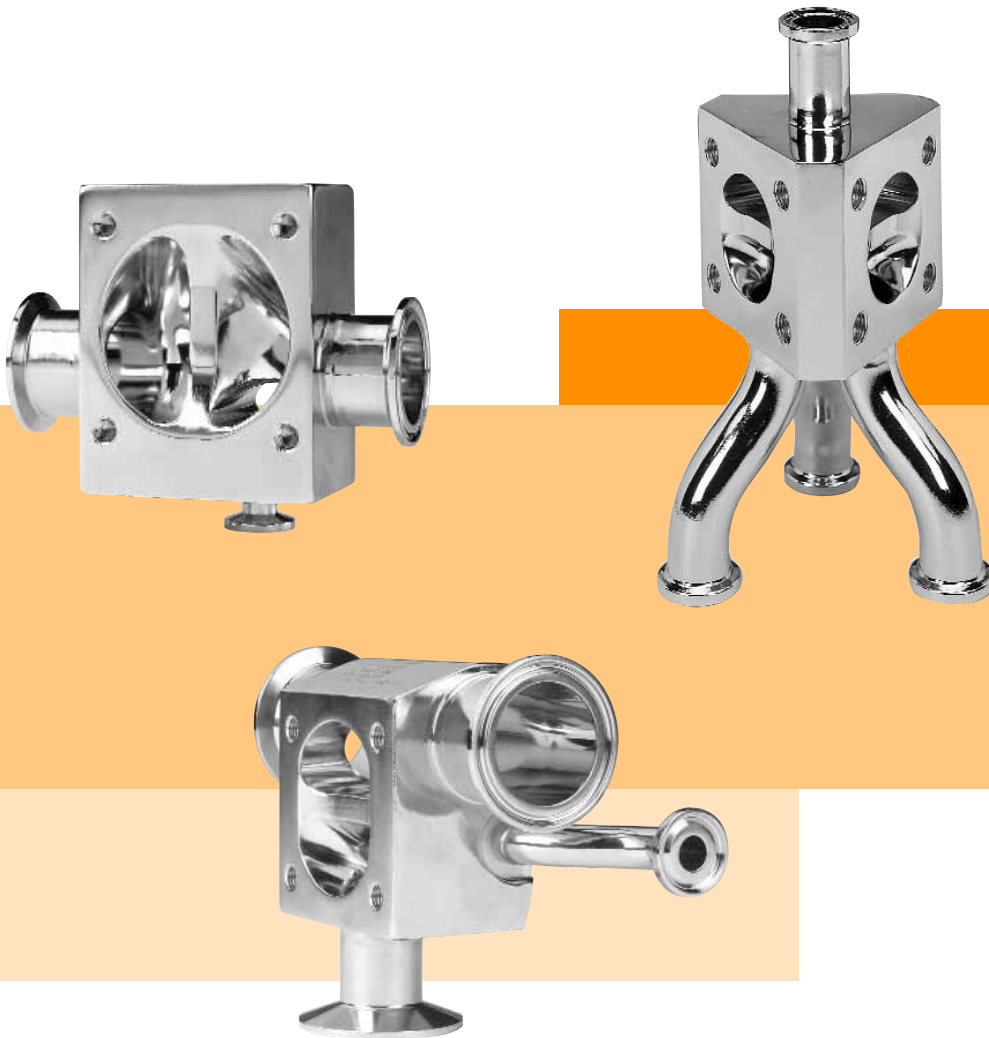




ITT

Pure-Flo®

# Modular Block Bodies

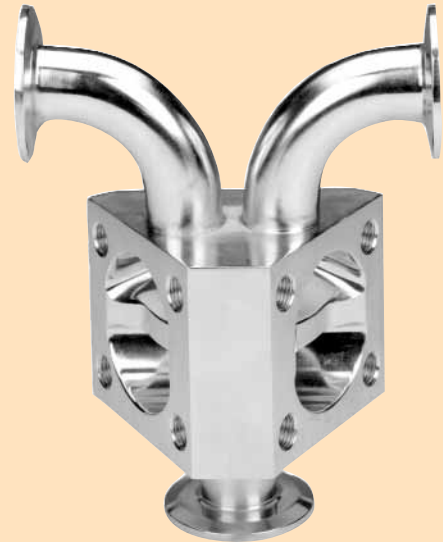
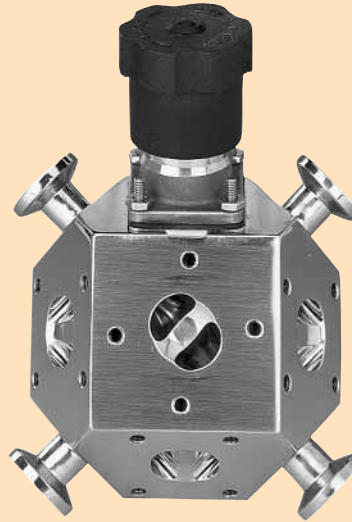


*Engineered for life*

[www.ittpureflo.com](http://www.ittpureflo.com)

# Table of Contents

Introduction	3
6D Rule vs. ASME BPE L/D	4-5
Zero Static Use Points	6
Zero Static Block Body	7
Zero Static Back to Back	
Sample Valve	7
Zero Static with Downstream Purge	7
Zero Static with Downstream and Upstream Purge	7
Special Zero Static Use Points	8
Divert/Mixing	9
2,3,4,5,6-Way Divert	10-11
Special Divert/Mixing Configurations	12
Chromatography	13
Integral Sterile Access Valves	
Integral Sterile Access and GMP	14
Integral Horizontal Sterile Access, Integral Dual Sterile Access and Crossover	15
Flow Control Valves	
Dual Flow, Bypass and Dual In Line	16
Vessel Valves	17
Tank Valves	18-19
Sterile Filter Shunt Valve	20
Sterile Barrier Valve and Block & Bleed	21
Special Application Valves and Custom Designs	22
Modular Assemblies	23
Process Applications	
High Purity Water	24
Chromatography	25
Fermentation/ Bioreactors	26-27
P&ID Cross Reference	28-29
Special Valve Request Form	30
Terms & Conditions	31



## Introduction

The Biopharmaceutical industry is under constant pressure to improve purity and efficiency of the drug manufacturing process.

Biopharm processes are complex and extremely sensitive to system and environmental factors. The purity and output of the manufacturing process can be greatly affected by the design of the system.

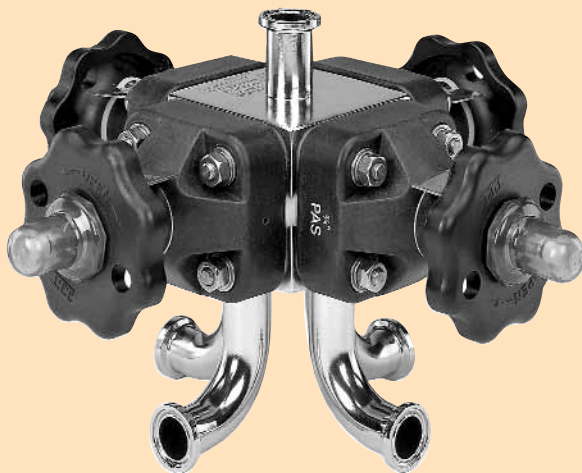
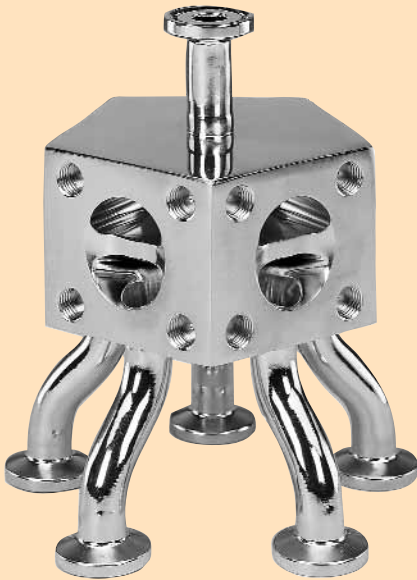
The Pure-Flo Solutions Group has a long history of developing innovative solutions to satisfy the needs of the Biopharm industry. Until recently, many piping challenges were solved by welding standard valve bodies into complex webs of piping. While these fabrications have served the industry well, there is a need for even better solutions.

Now with the common use of powerful 3D Modeling software, a wide variety of previously unthinkable solutions are available to the industry. 3D modeling allows the Pure-Flo Solutions Group to develop block body designs that meet the most demanding requirements for:

- Minimized internal volume
- Minimized hold-up and deadlegs
- Increased product purity
- Reduced CIP cycle times

The block body design concept is not only innovative, but cost effective. Pure-Flo block body designs have additional benefits of:

- Reducing installation time
- Reducing expensive field welds
- Minimizing process piping footprints
- Utilizing standard Pure-Flo actuation and diaphragms



## cGMP's – Current Good Manufacturing Practice

The cGMP regulation is a total quality concept applicable to processes and associated operations that assure the desired quality product. cGMP compliance, like quality, is fundamental and must be designed and built in from the earliest stages of a drug production project.

Drug manufacturers are required to maintain current Good Manufacturing Practices. This means that manufacturers must stay current with:

- New Technology
- New Methodology
- New Thinking
- New Requirements
- New Trends

One of the most critical factors in the production of drugs is the ability to clean and validate the drug production process. cGMP's require that processing equipment be designed to be cleaned and sterilized to minimize the potential for contamination, assuring the purity of the end drug product.

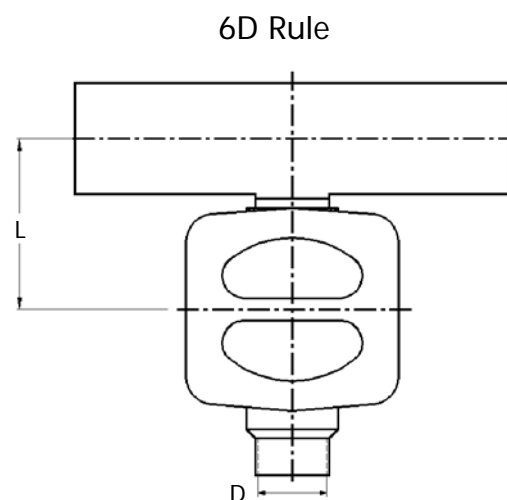
Hygienic weir style diaphragm valves have become the most important control element of process piping systems utilized in the Pharmaceutical and Bioprocessing industries. This valve has become the standard due its unique ability to provide drainability with minimized product entrapment areas. Modular block body valve designs take these characteristics to an even higher level.

## 6D Rule vs. ASME BPE L/D

### Dead-legs - What ever happened to 6D?

Basically, a "dead-leg" is defined as a one-way water system. Dead-legs result in process systems that are difficult to clean. The FDA reference document "GUIDE TO INSPECTIONS OF HIGH PURITY WATER SYSTEMS" indicates that dead-legs for hot (75-80°C) circulating water systems (self sanitizing) shall be no greater than 6 diameters of the unused pipe, measured from the axis of the pipe in use. Colder water systems (65-75°C) are not self sanitizing and therefore should eliminate dead-legs, if possible, or have special sanitizing procedures in place.

This 6D requirement has been the basic standard for many years when designing high purity water systems. Due to the method of measurement however, 6D as defined was not truly representative of what dead-leg characteristics are critical to designing a cleanable process piping system. Defining a dead-leg from the axis of the main pipe simply does not address the characteristics that affect the ability to clean and sanitize the dead-leg in question.

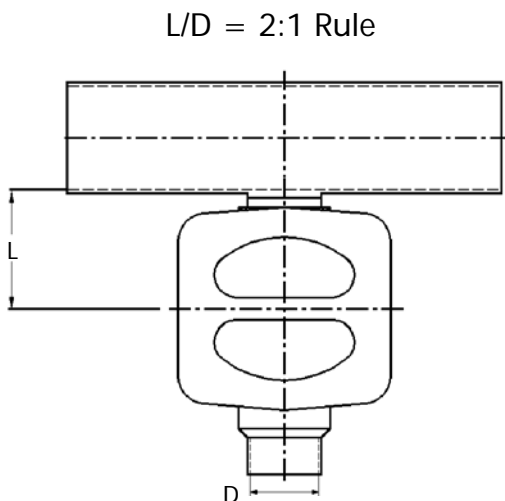


## ASME BPE L/D = 2:1

The Bioprocessing industry has found that 6D piping standards are not sufficient to assure optimal cleanable and sterilizable process systems. The sensitive nature of the production processes and the substantial value of the end product have required the industry to develop even more stringent requirements in critical systems. In 1997 the American Society of Mechanical Engineers (ASME) addressed this need by creating the ASME Bioprocessing Equipment Standard. The ASME BPE standard suggests that high purity water, clean steam systems and bioprocessing systems such as fermentation, purification and filtration systems can be designed to meet an L/D ratio of 2:1. L is defined as the Length of the dead-leg extension measured from the ID wall normal to the flow pattern. D is the nominal size dimension of the extension of a valve or instrument.

The ASME BPE standard states that the L/D ratio of 2:1 should be considered a target, not an absolute requirement, but the system designer/manufacturer should make every attempt to eliminate system dead-legs, and identify where exceptions exist.

Since the L/D ratio of 2:1 is a target, the system designer must make the determination of what L/D ratio is warranted for a particular system or project. In many cases L/D ratios of 2:1, 3:1 or sometimes 4:1 are utilized.



## Block Bodies and Total Cost of Ownership

Total cost of ownership for a process system can not be calculated by material costs alone. Installation and ongoing operational costs should be taken into account when making any component purchasing decision. In many cases the cost of modular block bodies are greatly offset by reductions in installation costs, space requirements and improvements in operational efficiency.

Modular Block Bodies can improve production efficiencies by:

- Minimizing internal valve volume
- Minimizing hold up
- Minimizing dead-legs
- Reducing CIP cycle times
- Increasing product purity
- Reducing qualification and validation efforts

Modular Block Bodies also reduce:

- Installation time and costs
- Expensive field welds
- Process piping footprint

# Zero Static Use Points

Zero Static use points are some of the most critical valves utilized in the Biopharmaceutical industry. Use point valves allow process fluids to be transferred, sampled, drained or diverted with minimal impact on critical systems such as WFI and purified water.

## Standard Sizes:

0.25" - 2" (DN 8 - 50) Valve size

0.5" - 4" (DN 15 - 100) Run size

\*Other sizes available upon request

## Materials:

316L ASTM - A479

DN 177440, 1.4435

AL6XN

Hasteloy C-22 & C-276

\*Other materials available upon request

## Standard End Connections:

14, 16, 18, 20 Gauge OD tubing

DIN/ISO

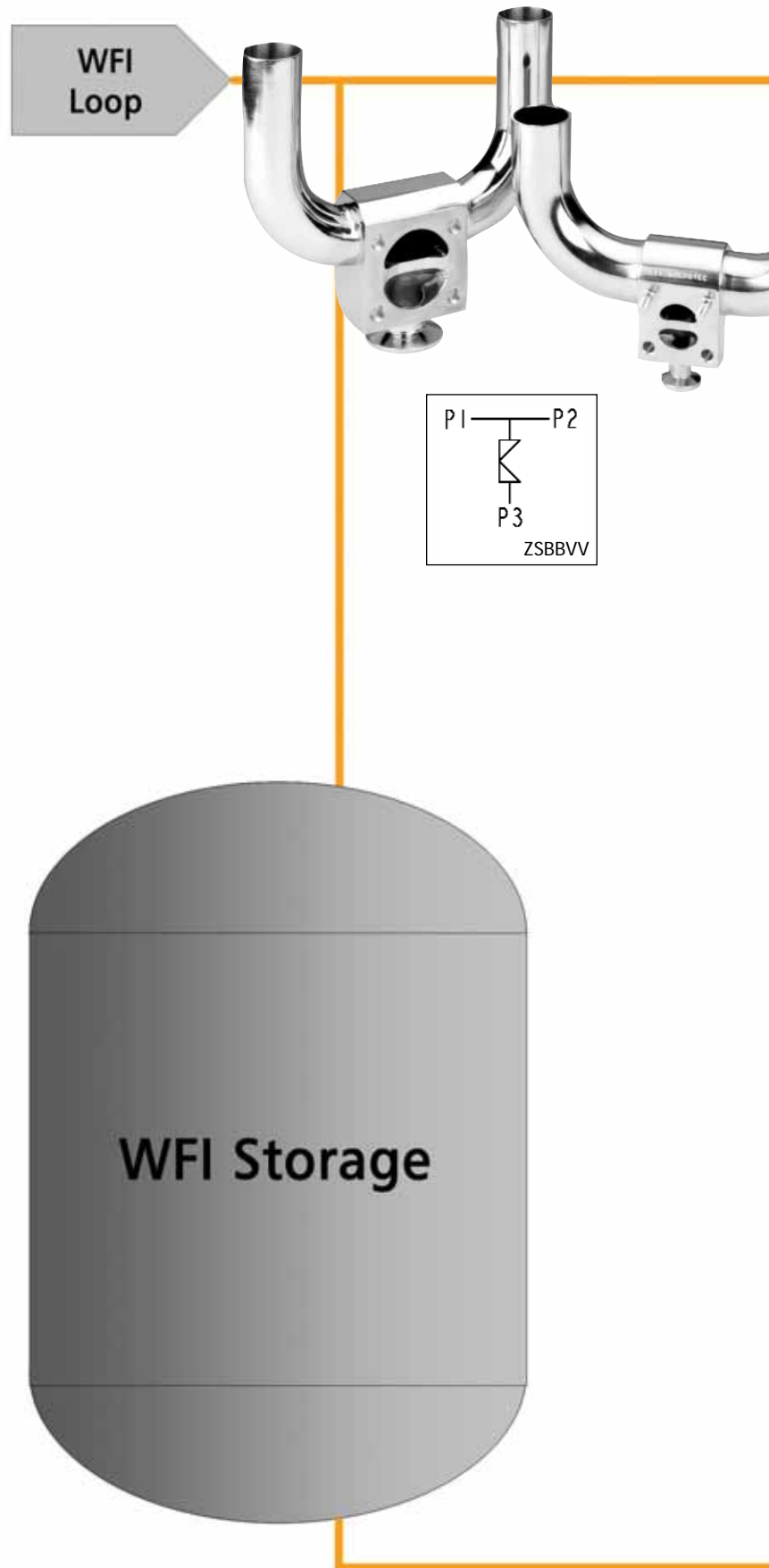
Tri-Clover Tri-Clamp®

\*Others available upon request

## Compatible with standard

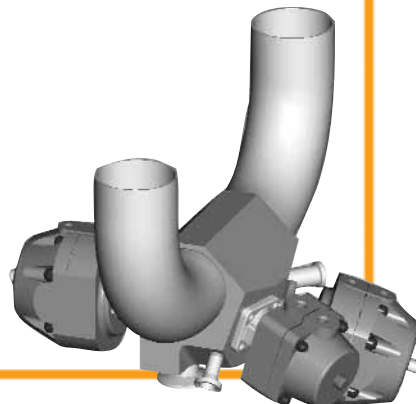
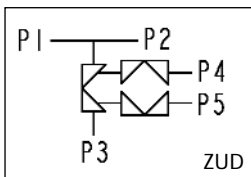
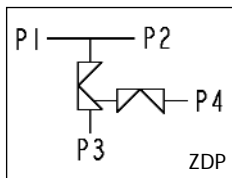
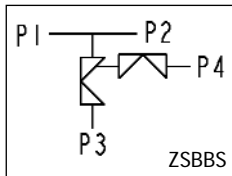
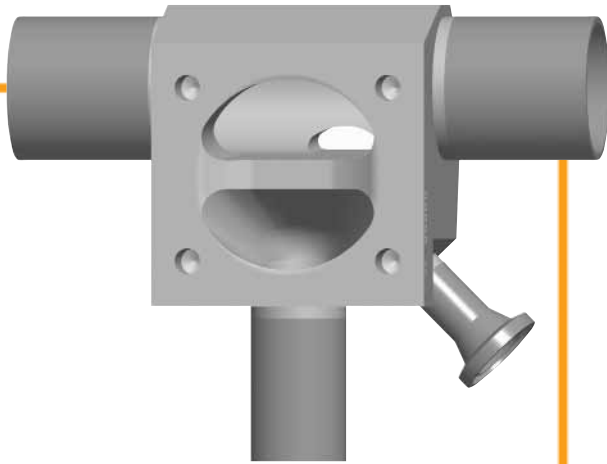
### Pure-Flo topworks:

\*See Pure-Flo Topworks brochure for details on available manual bonnets or actuators



Note: Schematic is for general pictorial reference only and should not be considered as recommended installation practice. Consult factory for installation recommendations.





## Zero Static Block Body

### Types:

ZSBBT - Zero Static Block Body Tee  
 ZSBBVV - Zero Static Block Body U-Bend, Vertical Tube, Vertical Valve  
 ZSBBHV - Zero Static Block Body U-Bend, Horizontal Tube, Vertical Valve

## Zero Static Back to Back Sample Valve

### Type:

ZSBBS - Zero Static Back to Back Sample Valve

### Typical Applications:

- Sampling of critical process systems at use point source prior to opening main valve.
- Sample outlet features a reducing ferrule to maximize drainability of small diameter ports

### Available Options:

- Standard 0.5" sample port end connection

## Zero Static with Downstream Purge

### Type:

ZDP - Zero Static Down Stream Purge

### Typical Applications:

- Steam purge prior to opening use point valve and/or air blow to remove downstream liquid
- Patent # 6,397,887

## Zero Static with Upstream Sample and Downstream Purge

### Type:

ZUD - Zero Static Upstream Sample/Downstream Purge

### Typical Applications:

- Multiple outlets from single block location, for sampling and purging
- Where sampling and separate sterilization purging is required

Note: All Zero Static block bodies are available as "T" or "U" bend configurations.

# Specialty Zero Static Use Points

## Type:

ZSBB with BO: Zero Static Tee with Back Outlet

## Typical Applications:

- For limited elevation applications

## Type:

ZID: Zero Static Inverted with Drain

## Typical Applications:

- For line feed applications that require the ability to drain the upstream line

## Type:

ZDI: Zero Static Dual Inline

## Typical Applications:

- To provide primary isolation for valve maintenance

## Type:

Integrated 5 Valve Zero Static Cluster

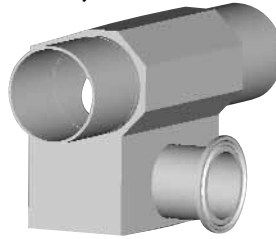
## Typical Applications:

- Consolidated multipoint utility service access

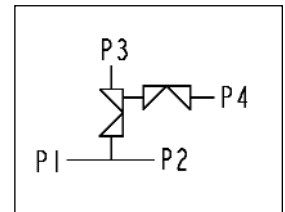
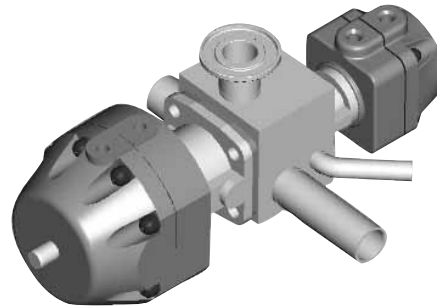
## Custom Zero Static Valves

When orientation, space constraints, drainability, valve maintenance, or other requirements affect your design, a variation of the Zero Static valve may be your solution. Let us know your requirements and we will design a valve for your application.

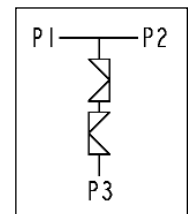
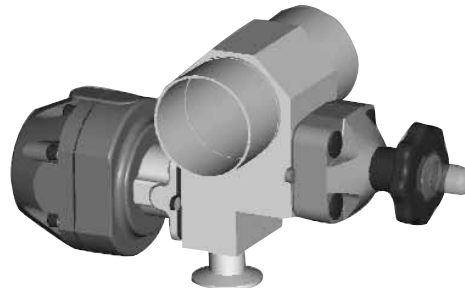
### Zero Static Tee with Back Outlet (ZSBB with BO)



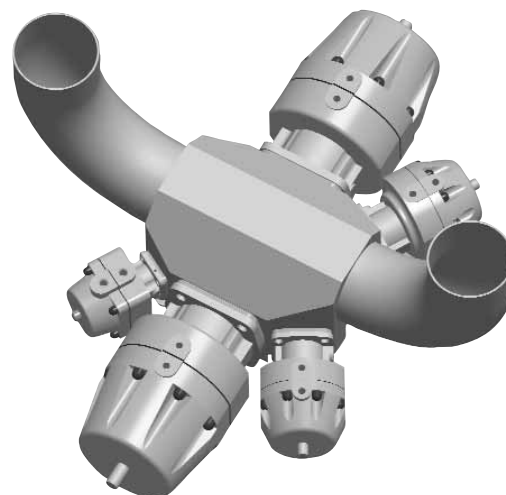
### Zero Static Inverted with Drain (ZID)



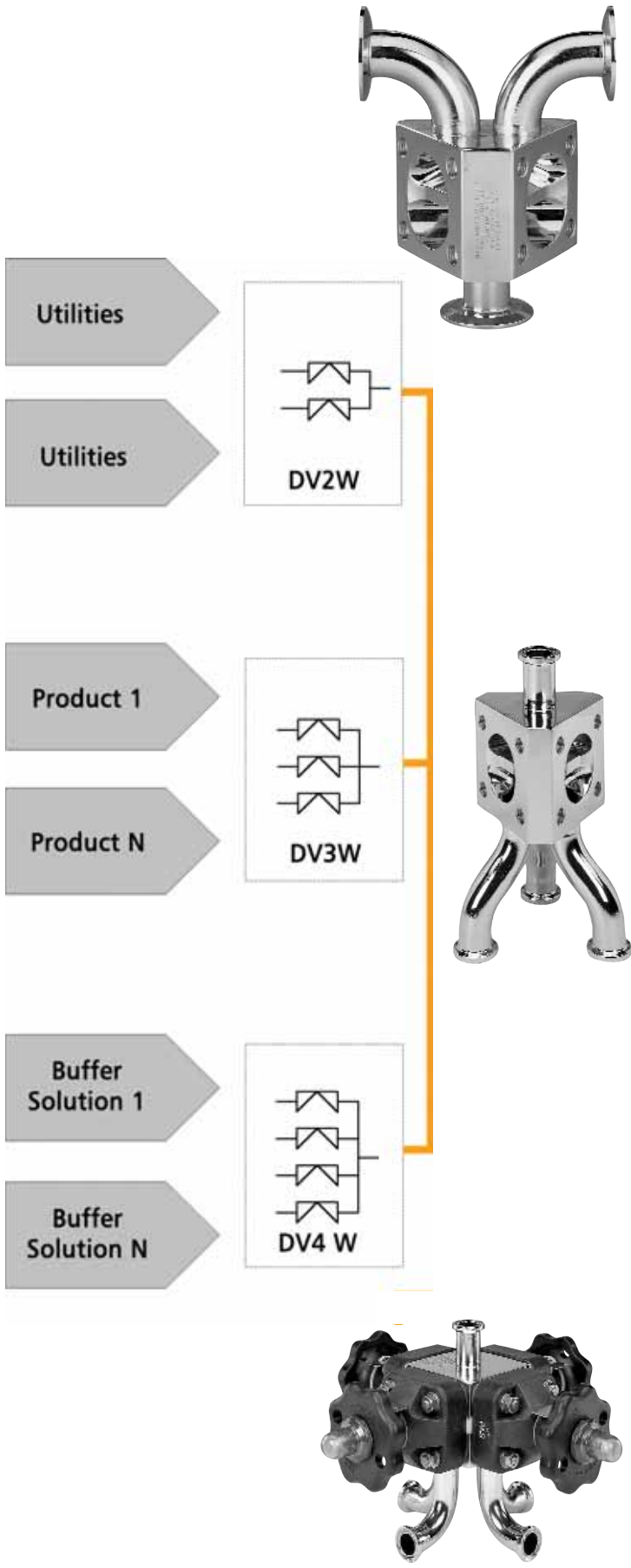
### Zero Static Dual Inline (ZDI)



### Integrated 5 Valve Zero Static Cluster







## Divert/Mixing

Multiport Divert valves are instrumental in achieving efficient, cost effective piping design. Divert valves allow process fluids to be diverted, mixed and/or sampled. Pure-Flo Solutions Group is the first in the industry to incorporate the multiple weir block design. The Divert valve is available in standard 2-, 3-, 4-, 5-, 6- way configurations as well as many special configurations. Key advantages to the Pure-Flo Divert valves are:

- Minimized contact surfaces & hold up volume
- Reduced CIP cycle times
- Improved product purity
- Minimized piping dimensional envelope
- Reduced number of system weldments
- More easily actuated and validated than transfer panels

### Standard sizes:

0.5" - 4" (DN15 - DN100)

\*Other sizes available upon request

### Materials:

316L ASTM - A479

DIN 177440, 1.4435

\*Other materials available upon request

### Standard End Connections:

14, 16, 18, 20 Gauge OD tubing

DIN/ISO

Tri-Clover Tri-Clamp (registered mark)

\*Others available upon request

### Compatible with standard Pure-Flo topworks:

\*See Pure-Flo Topworks brochure for details on available manual bonnets and actuators.

Patent for DV2W

6,237,637 and 5,427,150

[www.ittpureflo.com](http://www.ittpureflo.com)

# 2, 3, 4, 5, 6-Way Divert

**Type:**

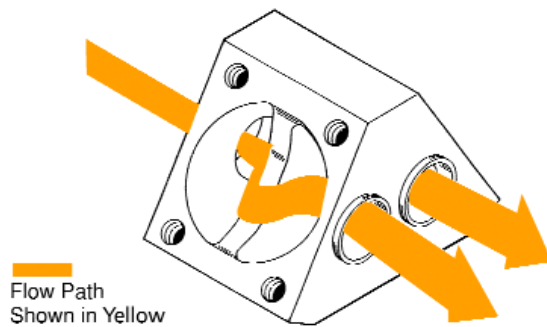
DV2W, DV3W, DV4W, DV5W, DV6W

**Typical Applications:**

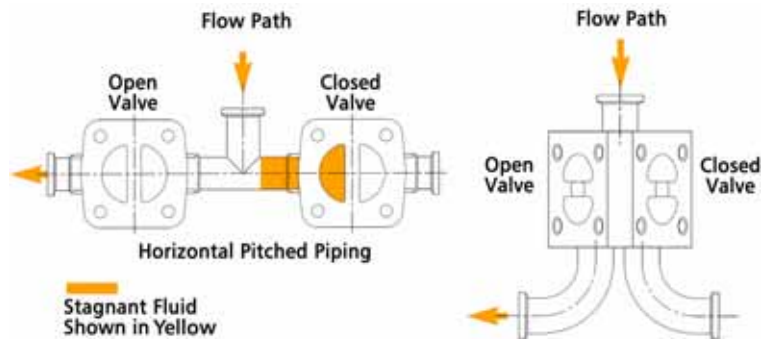
- Divert process flow, mixing flow paths
- Used in place of transfer panels
- Also used for bypass, drain and isolation

Divert valves can be ordered with threaded mounting holes to assist in installation. The 2-Way Pure-Flo Divert Valve may be positioned in a horizontal or vertical line, and is designed to optimize drainability.

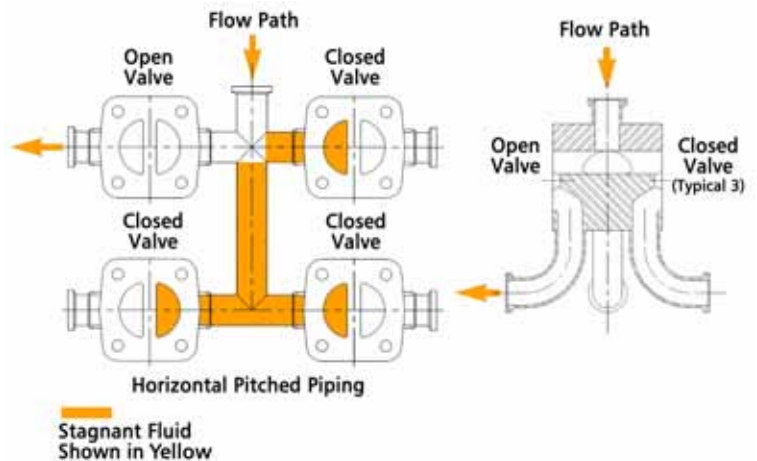
## 2-Way Divert Valve Horizontal Flow Path

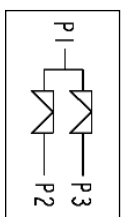
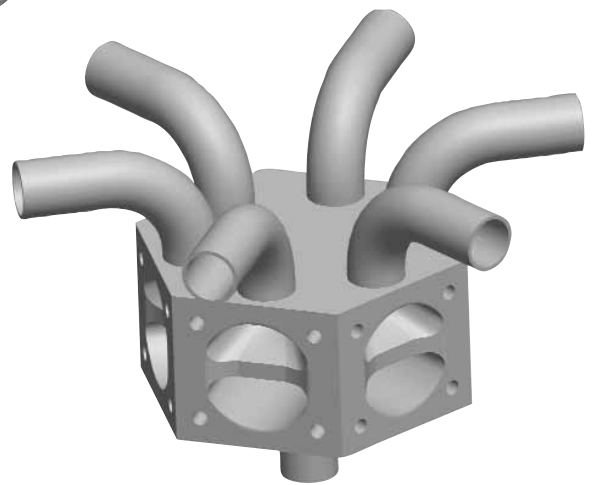


## Conventional Divert Valve Assembly vs. Pure-Flo 2 Way Divert Valve

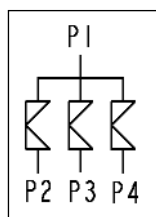


## Conventional Divert Valve Assembly vs. Pure-Flo 4 Way Divert Valve

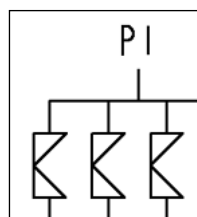




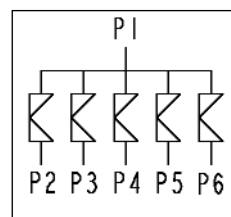
DV2W



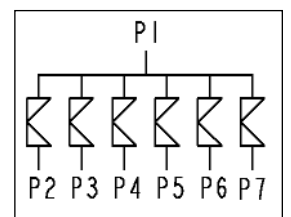
DV3W



DV4W



DV5W



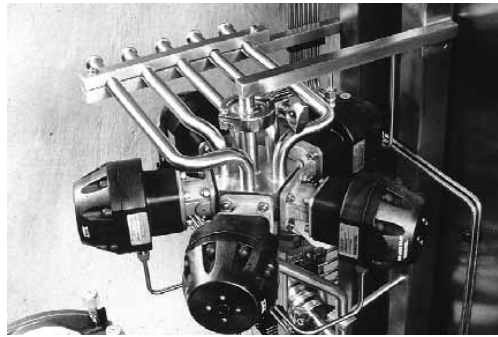
DV6W

# Special Divert/Mixing Configurations

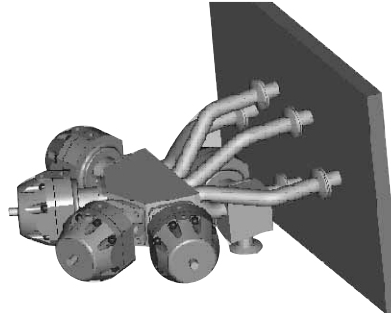
The Pure-Flo Solutions Group has a design team with in-depth knowledge and experience in creative valve solutions for Biopharm applications. By utilizing the power of 3D Computer Aided Design and our vast experience, the Pure-Flo design team will provide innovative solutions to your challenging problems.

Whether it is as simple as adding a special steam or drain port to an existing design, combining multiple valves into one unique product, or starting from scratch, the Pure-Flo Solutions Group is capable of turning your ideas into reality.

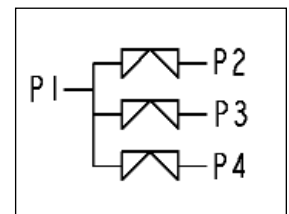
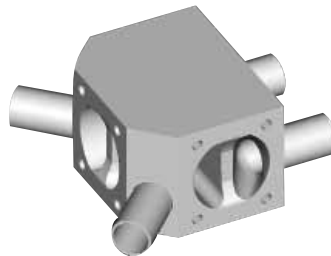
Skid Mounted 5-Way



Panel Mounted 4-Way Cleaning Valve



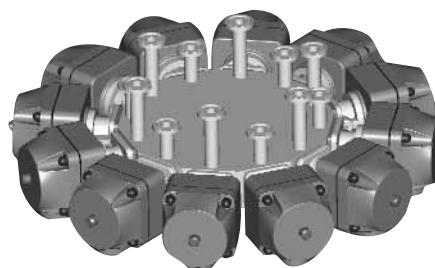
Horizontal 3-Way

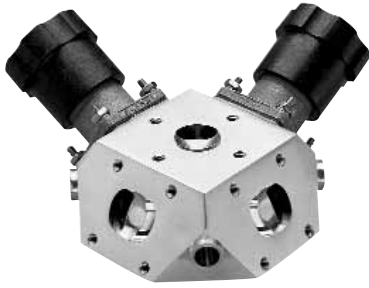


10-Inlet Valve Assembly  
(Two Stacked DV5W's)

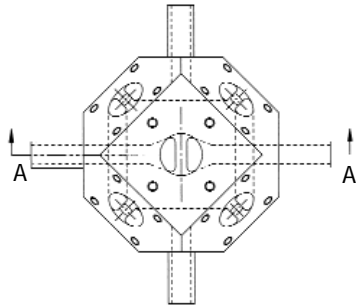


12-Way Divert





The Integral Chromatography Valve provides the process needs of three (3) P&IDs, utilizing four or five valves in one integrally machined assembly, dramatically reducing contact surfaces and hold up volume.

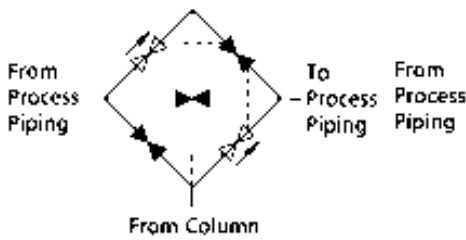


Section A-A

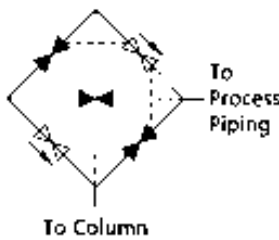


Figure 1

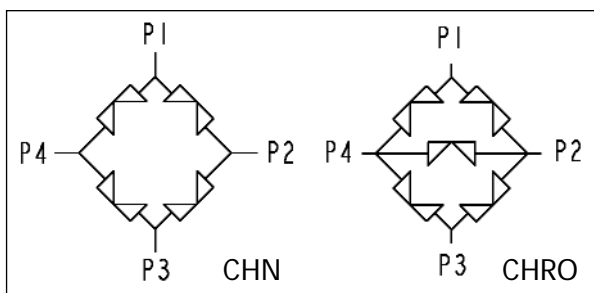
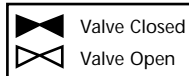
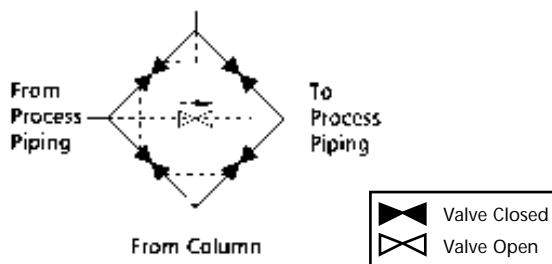
Option #1  
To Column



Option #2  
From Column



Option #3  
To Column



# Chromatography

In a typical chromatography process, there is an assembly of five diaphragm valves that connect the chromatography column to the process piping (see figure#1). Manipulating those valves allows the process to flow through the chromatography column in the forward and reverse direction, as well as bypass the column completely. The Pure-Flo Integral Chromatography Valve Assembly accomplishes this task, integrating the required valves, while retaining flexibility, minimizing dead legs in the process piping and reducing the overall space needed for the assembly.

**Type:**

- CHRO - Chromatography
- CHN - Chromatography without Bypass

Patent # 6,112,767 and 5,906,223

# Integral Sterile Access Valves

## Integral Sterile Access and GMP

**Type:**  
ISG

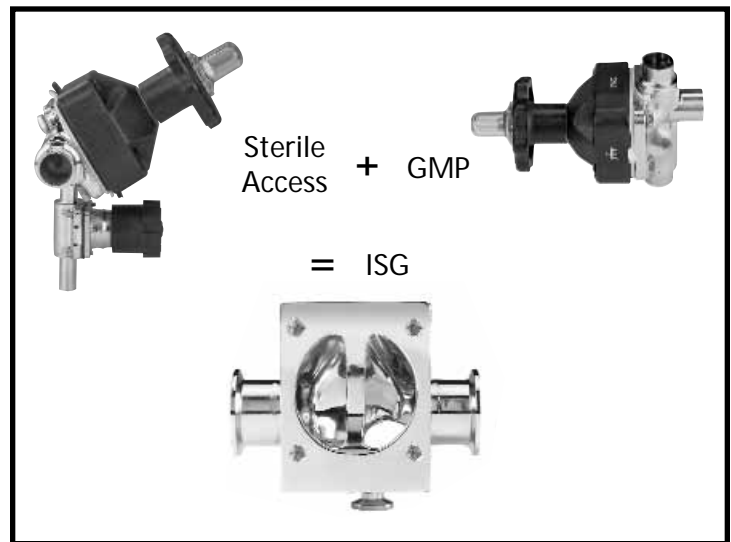
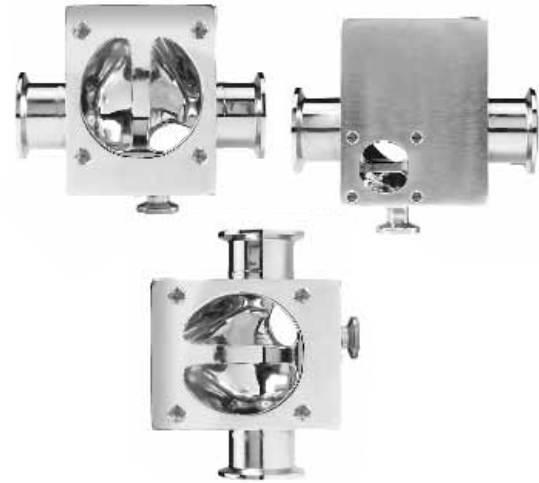
**Typical Applications:**

- Process diversion, steam barrier/block sampling

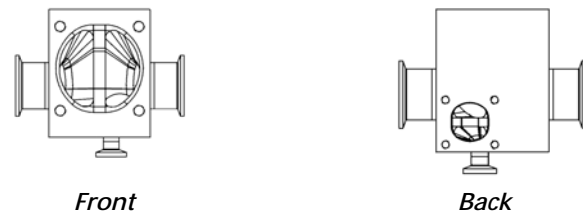
The ISG combines the functionality of the two most common process fabrications (Sterile Access (SA) and GMP) into one assembly, greatly reducing the dead legs of conventional SA and GMP fabrications when a purge valve is required.

This is achieved by providing the purge valve integral to the main body design. By simply rotating the assembly, one fabricated block body can provide three process fabrication orientations; Standard Sterile Access Port (SAP) and vertical GMP porting above and below the weir. The result is one integral valve assembly, which reduces contact surfaces and hold up volume, while minimizing dimensional envelope and increasing design flexibility.

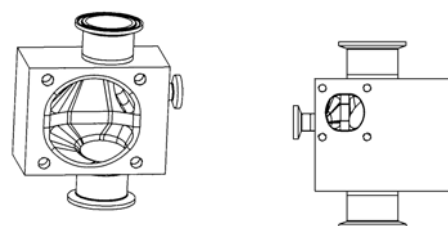
Patent # 6,401,756



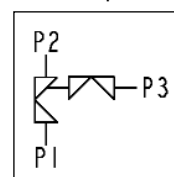
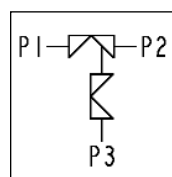
ISG (SAP Views) - Horizontal Installation



ISG (GMP Views) - Vertical Installation

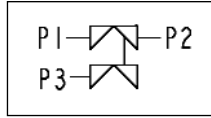
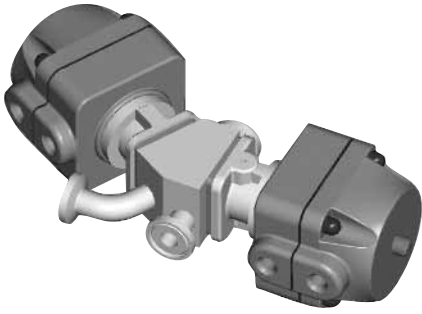


P&ID Options

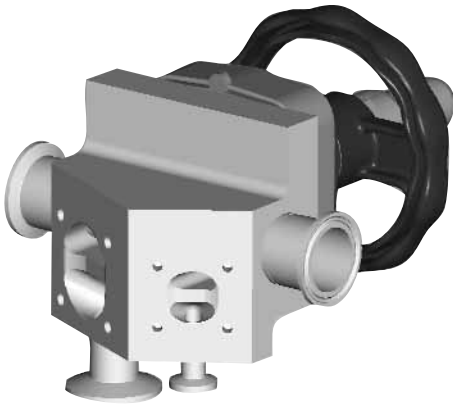




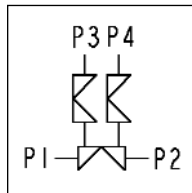
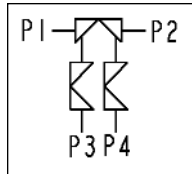
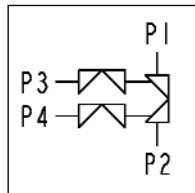
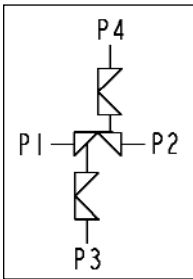
## Integral Horizontal Sterile Access (IHSA)



## Integral Dual Sterile Access (IDSA)



P&ID Options



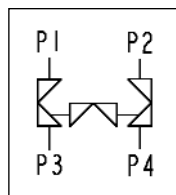
## Crossover



CRO



CROD



## Integral Horizontal Sterile Access

### Type:

IHSA

### Typical Applications:

- Integral block incorporating second horizontal valve
- Ideal for vertical space constraints

## Integral Dual Sterile Access

### Type:

IDSA

### Typical Applications:

- Equipment connection requiring dedicated up and down flow.

## Crossover

### Type:

CRO - Crossover (universally drainable in the vertical orientation)  
 CROD - Crossover with drain angle for horizontal applications

### Typical Applications:

- Isolation and bypass of equipment such as filters

# Flow Control

## Dual Flow

**Type:**

DF

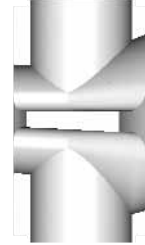
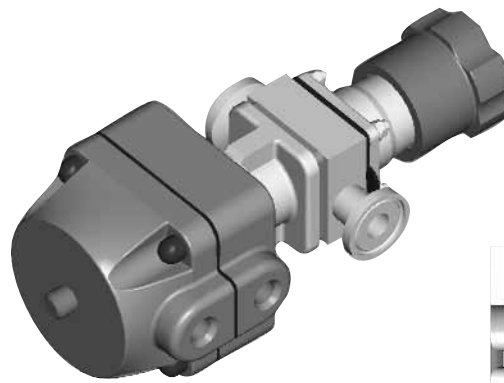
**Typical Applications:**

- Secondary internal valve to provide alternate flow rate / assure some flow in backup path (WFI)

**Available Options:**

- Main and secondary valves in various sizes.

## Dual Flow (DF)



Dual Flow Path Section

## Bypass

**Type:**

BYP

**Typical Applications:**

- Secondary internal valve to provide alternate flow rate for macro and micro flow requirements. Often used for tank filling applications.

**Available Options:**

- Bio-Tek secondary valve

## Bypass (BYP)



## Dual In Line

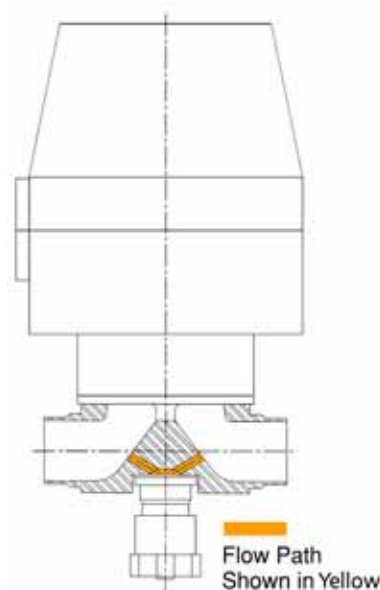
(not pictured)

**Type:**

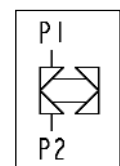
DIL

**Typical Applications:**

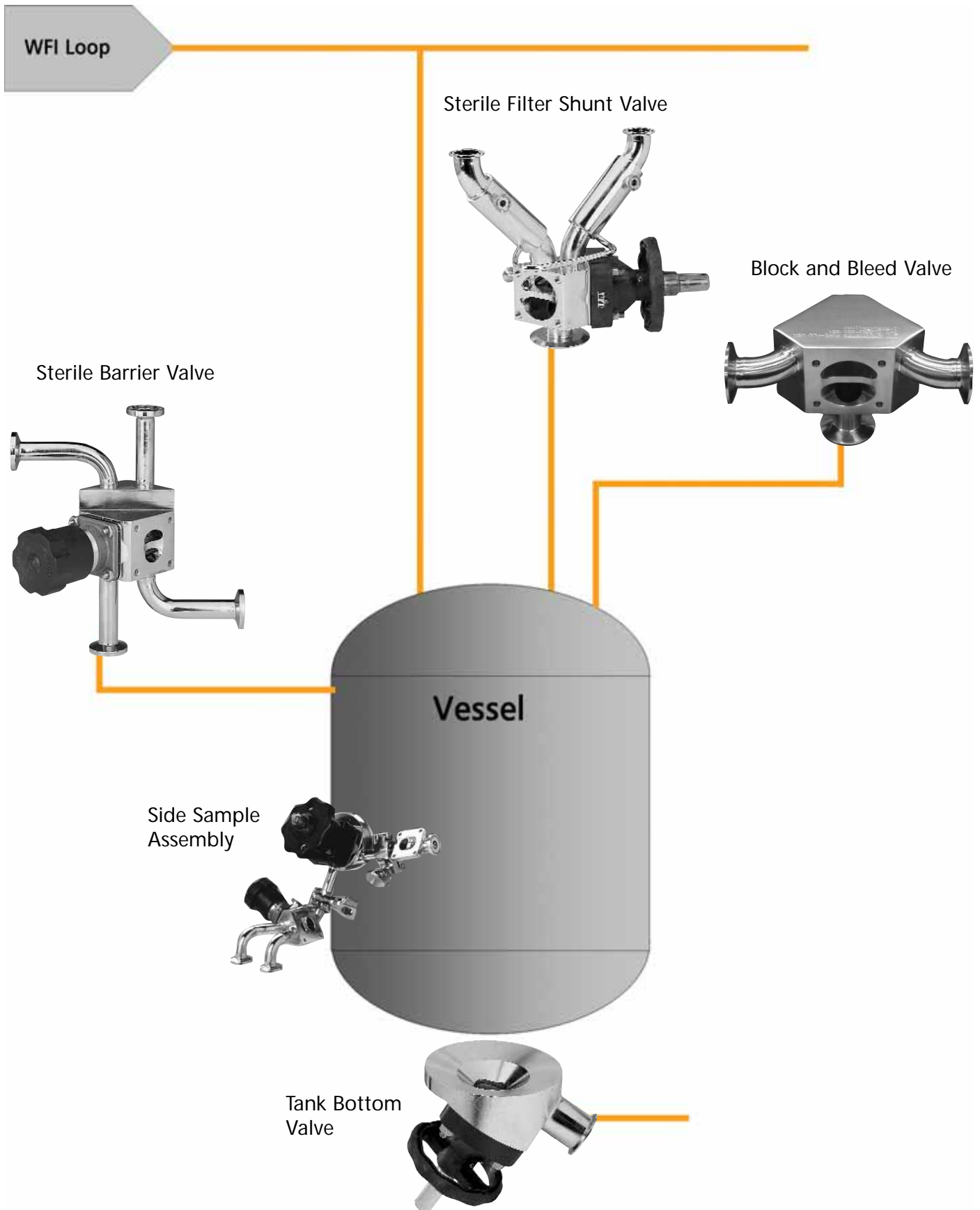
- Isolation of critical valve



Bypass Flow Path Section



# Vessel Valves



Note: Schematic is for general pictorial reference only and should not be considered as recommended installation practice. Consult factory for installation recommendations.

# Tank Valves

## Tank Bottom Valve

**Type:**  
TBV

**Size Range:** 1/2"-4" (DN 15-100)

**Body Material:**  
316L Stainless Steel Bar Stock  
ASME SA-479  
(UNS S31603), 1/2"-4" (DN 15-100)  
\*Other materials available upon request

The Tank Bottom Diaphragm Valve is designed for use at the bottom of a tank or vessel to drain or sample while minimizing the interior sump and preventing any dead leg for bacteria or microorganism entrapment.

### Tank Connection:

The tank interface surface is designed for a weld attachment. However, ANSI flanges can be ordered upon request.

### Drain Port End Connections:

Standard outlet port is oriented 30° down from horizontal. A 45° angle is available upon request.

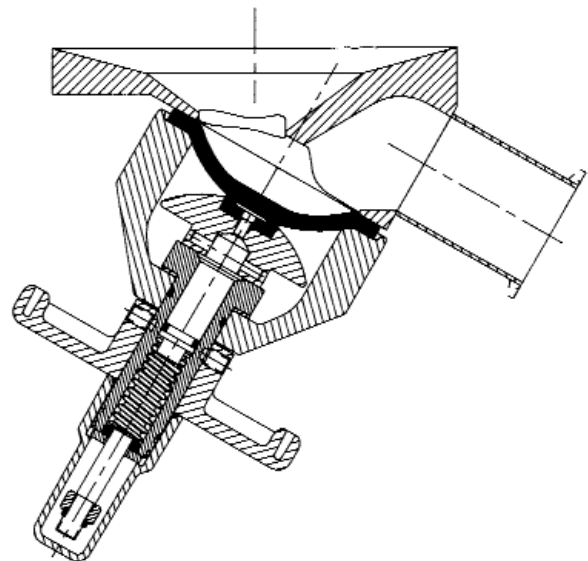
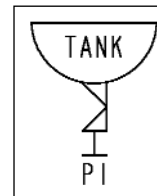
### Buttweld:

- 14, 16 Gauge O.D. Tubing, dependent on size.
- Schedule 5, 10, and 40 Pipe Quick Disconnect
- Tri-Clover Tri-Clamp
- Cherry Burrell "S", "Q", and "I" line®
- Superior Stainless, Valex and G&H ferrules

### Design Compliance:

ASME Boiler and Pressure Vessel Code Section VIII, Division #1.

Patent # 5,227,401

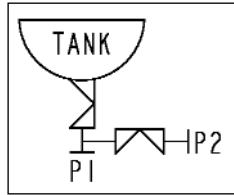
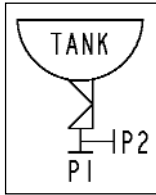


## Special Tank Valves

Tank valves are also available in a variety of configurations.

### Available Options:

- Multiple integral valves
- SIP ports
- CIP ports
- Sample valves
- Vessel side mounting



## Multiple Integral Valve Tank Bottom Valve



## Side Mounted Sterile Sample Valve Assembly



# Sterile Filter Shunt Valve

**Type:**  
DV2WS

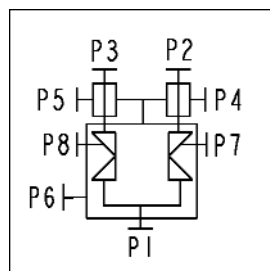
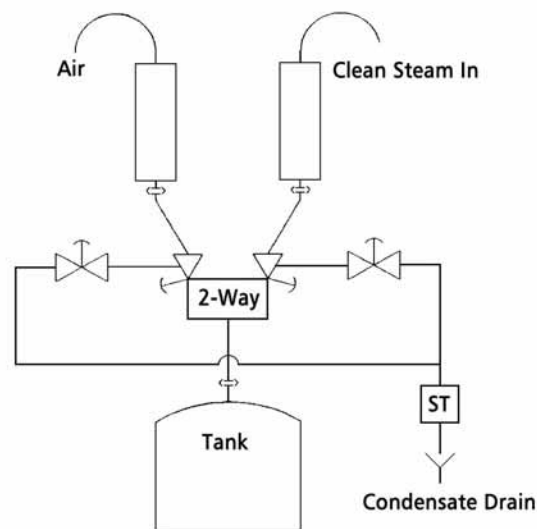
Changing a vent filter cartridge on a WFI tank while the system is in operation is normally not possible due to the likelihood of contaminants entering the tank. Smaller systems can be shut down for a short period of time, and with the use of a sterilizable upstream block diaphragm valve, restarted after steam sterilization of the housing, cartridge, connecting tubing, and upstream section of the valve. Large systems designed for continuous use require two separate vent filtration units. The sterile filter shunt valve is a sterilizable tank vent shunt valve assembly mounted on a single nozzle designed for this specific purpose.

A steam traced version of this valve is also available which, when used in conjunction with a steam jacketed filter housing, will prevent condensation from forming inside the housing. The assembly consists of two diaphragm valves with a common downstream port. The upstream side of the valves is connected to the two filter housings. The common port is connected to the tank vent nozzle. A steam condensate discharge port is positioned tangential to the weir of both valves. Two additional diaphragm valves are used to close the condensate port after sterilization. These valves in turn are connected to a steam trap which then goes to drain.

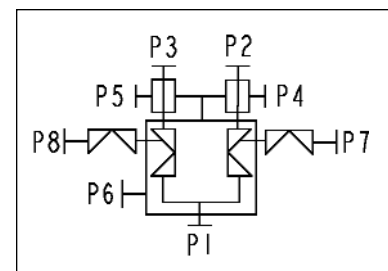
Available in 1 1/2" and 2" valve sizes (DN 40 and DN 50). Valve can be adapted for larger tank port sizes.



The Sterile Tank Vent Filter Shunt Valve is a steam traced 2-Way divert valve designed to provide the flexibility of changing from one vent filter cartridge to another on WFI storage tanks without interrupting operations.



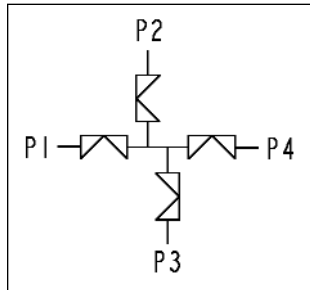
DV2WS



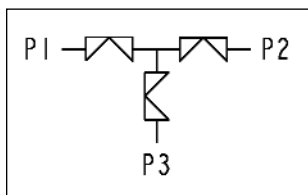
DV2WS with Condensate Drain Valves



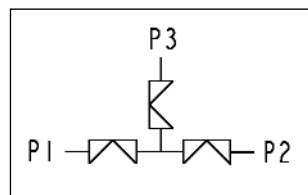
## Sterile Barrier (SB1)



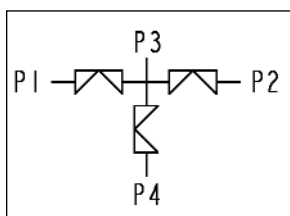
## Block and Bleed (BBD, BBV)



BBD



BBV



BBD with Vent Port

## Sterile Barrier Valve

### Type:

SB1 - Sterile Barrier Valve

The Pure-Flo Sterile Barrier design addresses the issues of achieving sterile barrier technology, utilizing a small dimensional envelope while minimizing contact surfaces and hold up volume.

The Integral Sterile Barrier assembly consists of four valves machined from a single block of stainless steel. The common chamber is located in the center of the assembly and the independent ports are located on the ends of the assembly. The assemblies consist of two product valves, a steam injection valve and a condensate drain valve. When the two product valves are open and the steam injection and condensate valves are closed, product flows through to the reactor. When the product valves are closed, a chamber is formed between the two divert valves which, when injected with steam, provides a sterile barrier isolating the reactor.

## Block and Bleed

### Type:

BBD - Block and Bleed Drain

BBV - Block and Bleed Vent

### Typical Applications:

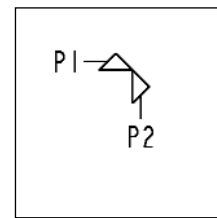
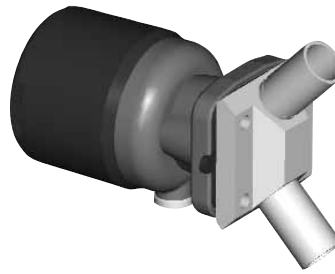
- Create steam block, isolate and clean chamber for aseptic barrier
- Block line flow for the purpose of draining the line or filling from an auxiliary source

# Special Application Valves and Custom Designs

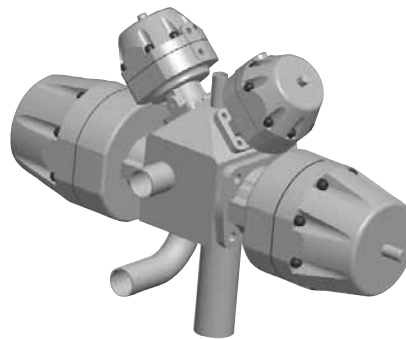
Whether it is as simple as adding a special steam or drain port to an existing design, combining multiple valves into one unique product, or starting from scratch, the Pure-Flo Solutions Group is capable of turning your ideas into reality. See the "Special Valve Request Form" on page 30.

Extensive 3D modeling capabilities allows the Pure-Flo Solutions Group to design innovative solutions for your specific use point requirements. A Pure-Flo representative will guide you to an efficient and cost effective design for your unique situation. If you can dream it, we can make it.

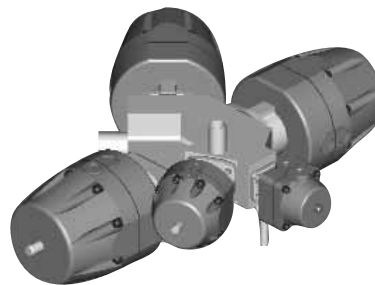
M90



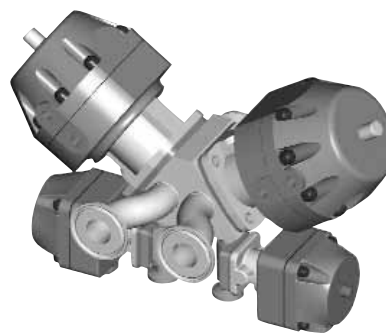
Special Process - Integrated 4 Valve



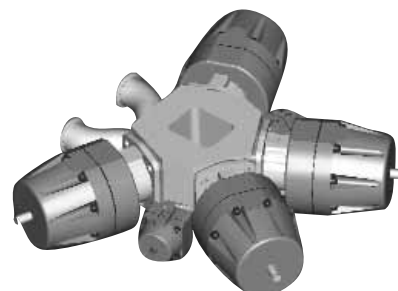
Special Process - Integrated 5 Valve



2Way Divert with Dual Port Valves



Special Distribution Valve

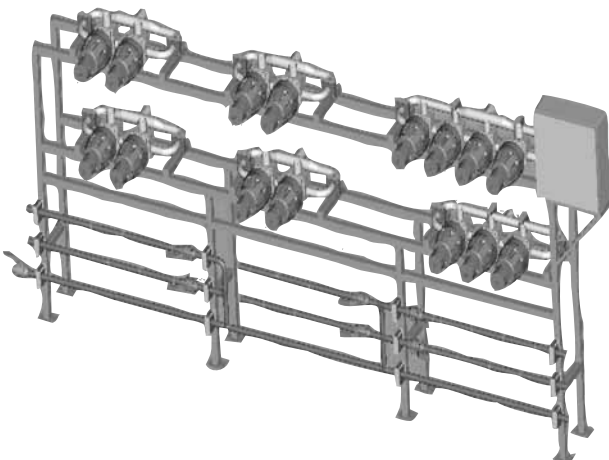
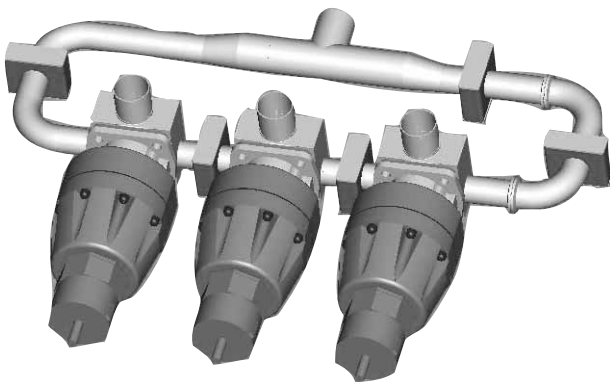
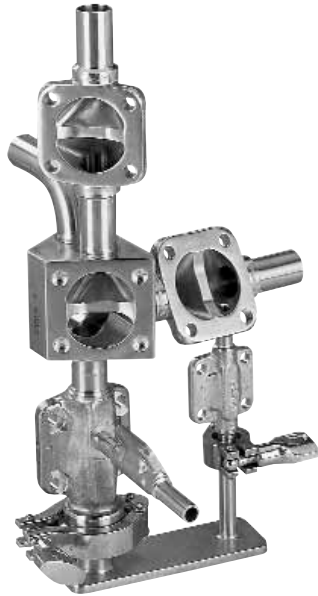


## Modular Assemblies

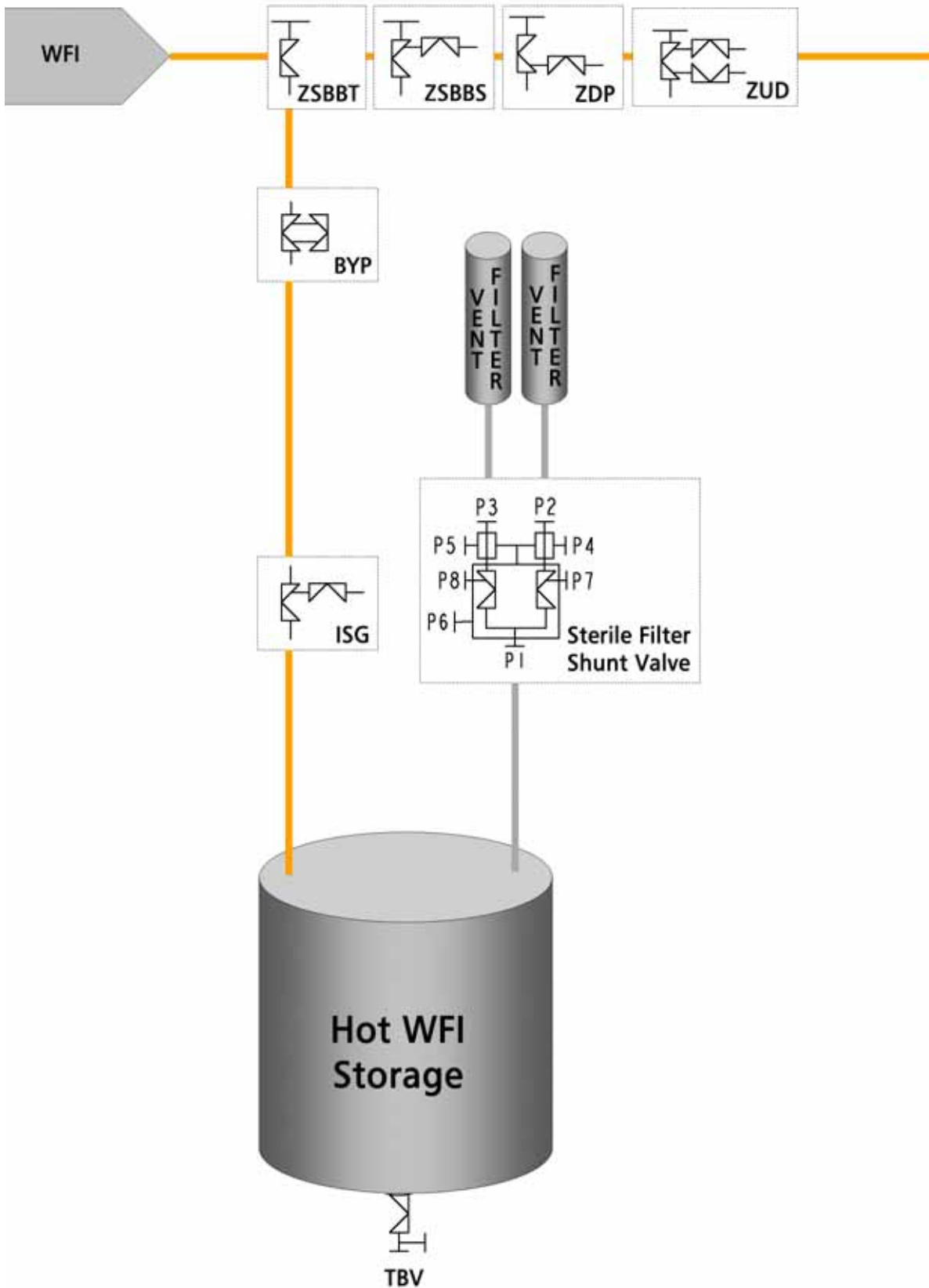
Custom modular valve assemblies are available. Our trained field sales personnel can assist in the review of your P&IDs and suggest possible combinations of valves into modular assemblies. The result is a cost competitive engineered assembly, which by design:

- Reduces contact surfaces, hold-up volume and dimensional envelopes
- Minimizes the cost, logistics and time of field construction
- Reduces weldments
- Provides an installation-ready assembly, pre-tested and qualified by the manufacturer

Note: A weld log, map, and boroscope information is available upon request.

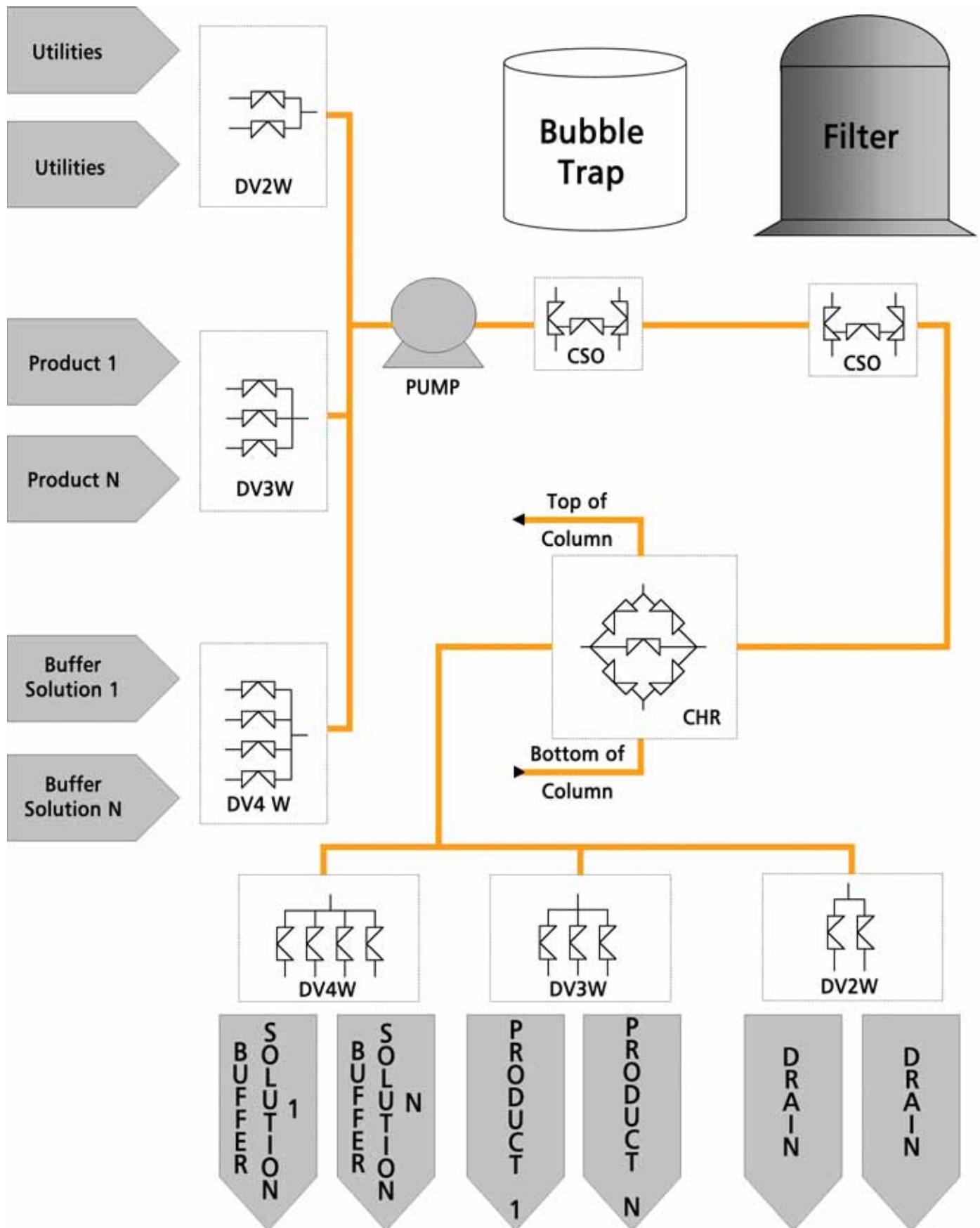


# Process Applications: High Purity Water Systems



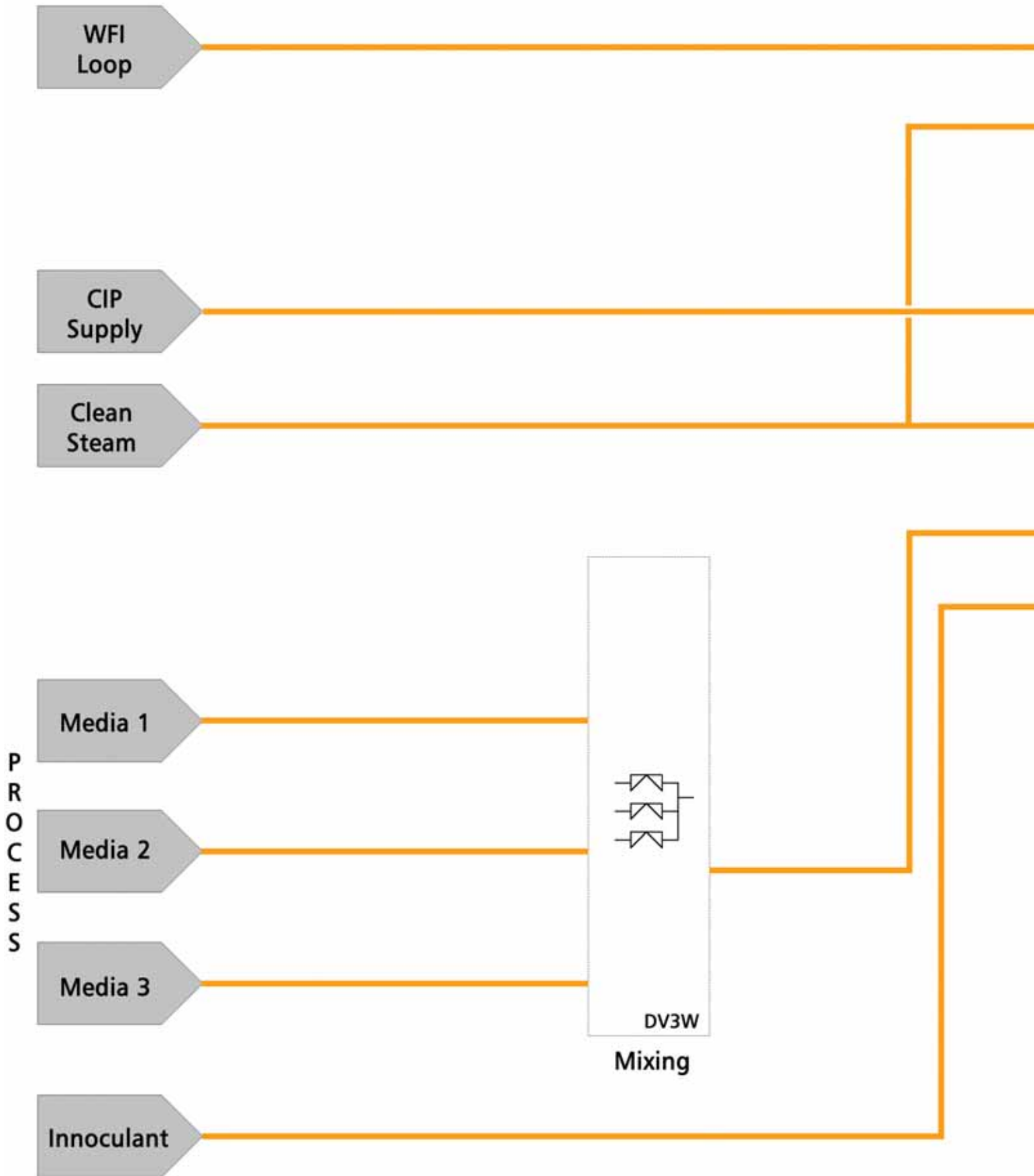
Note: Schematic is for general pictorial reference only and should not be considered as recommended installation practice. Consult factory for installation recommendations.

# Process Applications: Chromatography

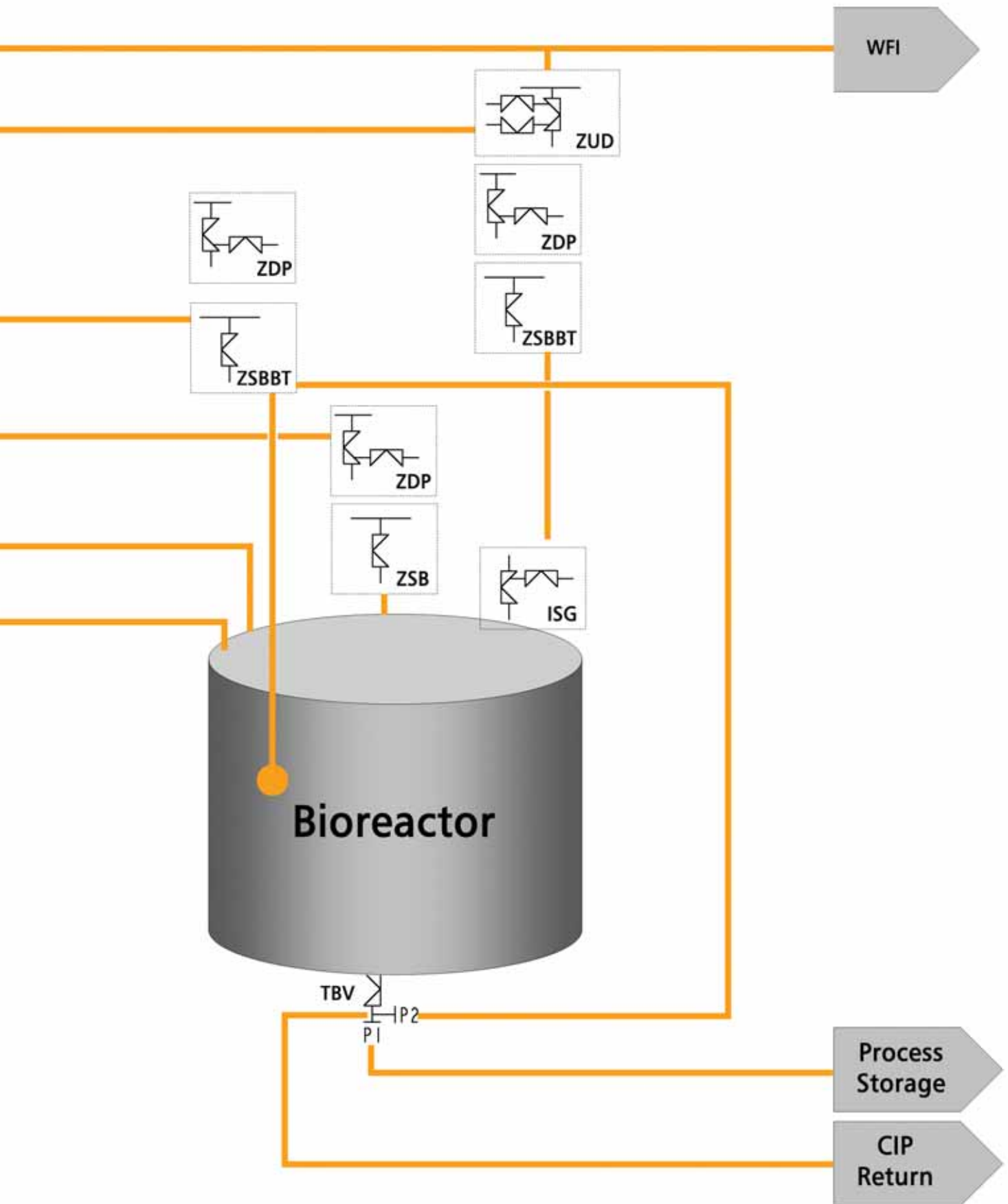


Note: Schematic is for general pictorial reference only and should not be considered as recommended installation practice. Consult factory for installation recommendations.

# Process Applications: Fermentation/Bioreactor



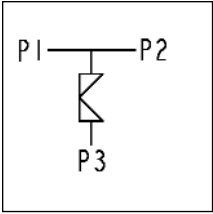




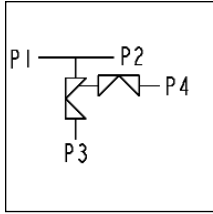
Consult factory for installation recommendations.

# P&ID Cross Reference

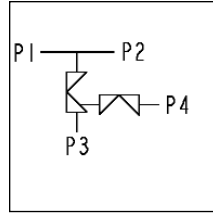
## Use Points and Sampling



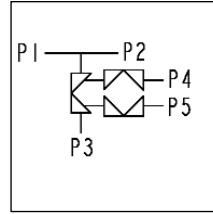
Zero Static Block Body  
Code: ZSBB



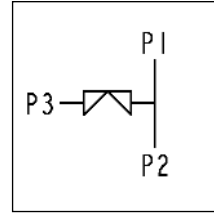
Zero Static Back to Back Sample  
Code: ZSBS



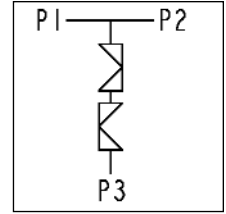
Zero Static with Downstream Purge  
Code: ZDP



Zero Static with Upstream Sample and Downstream Purge  
Code: ZUD

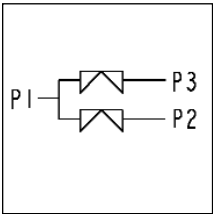


Zero Static Block Body with Vertical Run  
Code: ZSBV

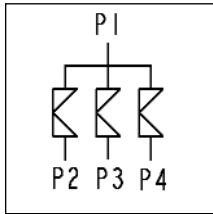


Zero Static Dual Inline  
Code: ZDI

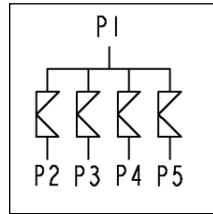
## Mixing/Divert Valves



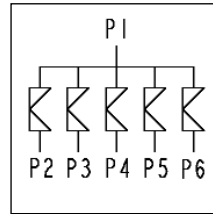
2-Way Divert Valve  
Code: DV2W



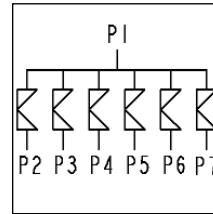
3-Way Divert Valve  
Code: DV3W



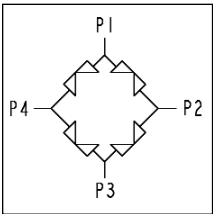
4-Way Divert Valve  
Code: DV4W



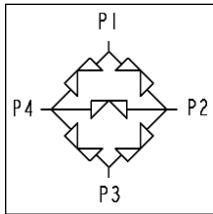
5-Way Divert Valve  
Code: DV5W



6-Way Divert Valve  
Code: DV6W

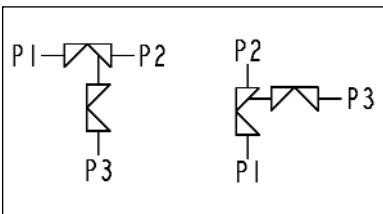


Chromatography without Bypass  
Code: CHN

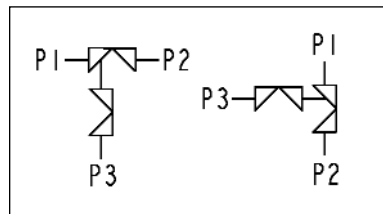


Chromatography with Bypass  
Code: CHRO

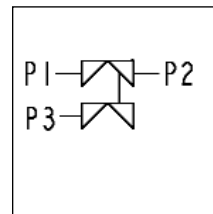
## Sterile Access Valves



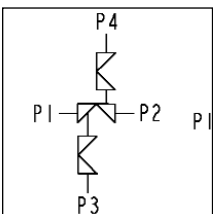
Integral Sterile Access and GMP  
Code: ISG



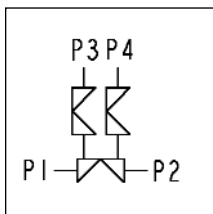
Integral Sterile Access and GMP  
Code: ISG



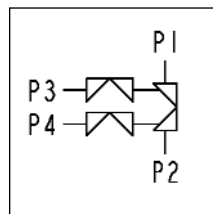
Integral Horizontal Sterile Access  
Code: IHSA



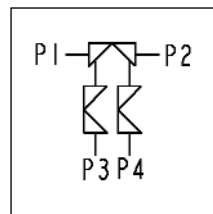
Integrated Dual Sterile Access  
Code: IDSA



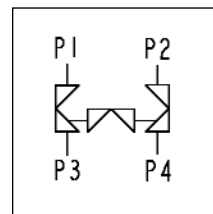
Integrated Dual Sterile Access  
Code: IDSA



Integrated Dual Sterile Access  
Code: IDSA



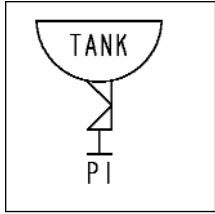
Integrated Dual Sterile Access  
Code: IDSA



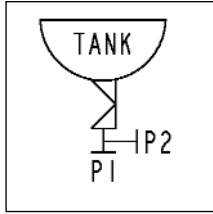
Crossover  
Code: CRO/CROD

# P&ID Cross Reference

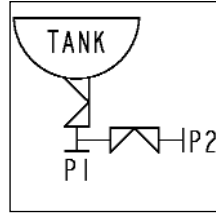
## Vessel Valves



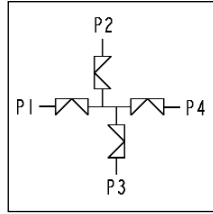
Tank Bottom Valve  
Code: TBV



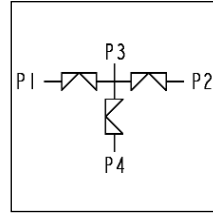
Tank Bottom Valve with CIP/SIP Port  
Code: TBV



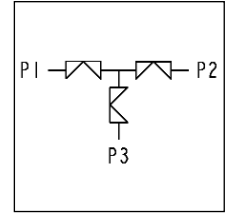
Tank Bottom Valve with CIP/SIP Valve  
Code: TBV



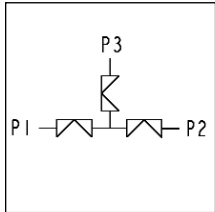
Sterile Barrier  
Code: SB1



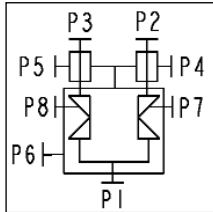
Block & Bleed with Vent Port  
Code: BBD



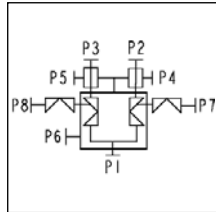
Block & Bleed  
Code: BBD



Block & Bleed  
Code: BBV

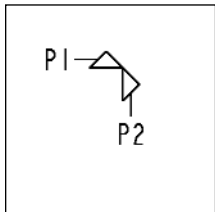


Sterile Filter Shunt Valve  
Code: DV2WS

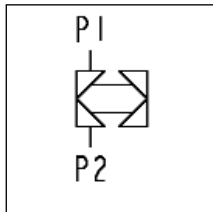


Sterile Filter Shunt Valve with Condensate Drain Valves  
Code: DV2WS

## Specialty Valves



90 Degree Elbow Valve  
Code: M90



Bypass or Dual Flow Valve  
Code: BYP or DF



# Terms and Conditions of Sale

## CONDITIONS and TERMS of SALE of ITT INDUSTRIAL & BIOPHARM GROUP (IBG) (hereinafter referred to as Seller)

**WARRANTY** - Company warrants title to the product(s) and, except as noted with respect to items not of Company's manufacturer, also warrants the product(s) on date of shipment to Purchaser, to be of the kind and quality described herein, and free of defects in workmanship and material. **This warranty is expressly in lieu of all other warranties, including but not limited to implied warranties of merchantability and fitness, and constitutes the only warranty of the company with respect to the product(s).**

If within one year from date of initial operation, but not more than eighteen months from date of shipment by Company of any item of product(s), Purchaser discovers that such item was not as warranted above and promptly notifies Company in writing thereof. Company shall remedy such nonconformance by, at Company's option, adjustment or repair or replacement of the item and any affected part of the product(s). Purchaser shall assume all responsibility and expense for removal, reinstallation, and freight in connection with the foregoing remedies. The same obligations and conditions shall extend to replacement parts furnished by Company hereunder. Company shall have the right of disposal of parts replaced by it. Purchaser agrees to notify Company, in writing, of any apparent defects in design, material or workmanship, prior to performing any corrective action back chargeable to the Company. Purchaser shall provide a detailed estimate of the material, labor costs associated with proposed remedy for expeditious review and approval by the Company.

Seller neither assumes, nor authorizes any person to assume for it, any other obligation in connection with the sale of its engineering designs or products. This warranty shall not apply to any products or parts of products which (a) have been repaired or altered outside of Seller's factories or authorized service centers, in any manner; or (b) have been subjected to misuse, negligence or accidents; or (c) have been used in a manner contrary to Seller's instructions or recommendations. Seller shall not be responsible for design errors due to inaccurate or incomplete information supplied by Buyer or its representatives.

**Any separately listed item of the product(s) which is not manufactured by the company is not warranted by the company** and shall be covered only by the express warranty, if any, of the manufacturer thereof.

**This states purchaser's exclusive remedy against company and its suppliers relating to the product(s), whether in contract or in tort or under any other legal theory, and whether arising out of warranties, representations, instructions, installations or defects from any cause.** Company and its suppliers shall have no obligation as to any product which has been improperly stored or handled, or which has not been operated or maintained according to instructions in Company or supplier furnished manuals.

**LIMITATION OF LIABILITY** - Neither Company nor its suppliers shall be liable, whether in contract or in tort or under any other legal theory, for loss of use, revenue or profit, or for cost of capital or of substitute use or performance, or for incidental, indirect, or special or consequential damages, or for any other loss or cost of similar type, or for claims by Purchaser for damages of Purchaser's customers. Likewise, Company shall not, under any circumstances, be liable for the fault, negligence, or wrongful acts of Purchaser or Purchaser's employees, or Purchaser's other contractors or suppliers.

**In no event shall company be liable in excess of the sales price of the part(s) or product found defective.**

**GENERAL** - (a) Company will comply with all laws applicable to Company. Compliance with OSHA or similar federal, state or local laws during any operation or use of the product(s) is the sole responsibility of Purchaser. (b) The laws of the State of New York shall govern the validity, interpretation and enforcement of any contract of which these provisions are a part, without giving effect to any rules governing the conflict of laws. (c) This document and any other documents specifically referred to as being a part hereof, constitute the entire contract on the subject matter, and it shall not be modified except in writing signed by both parties. Unless otherwise specified, any reference to Purchaser's order is for identification only. Assignment may be made only with written consent of both parties.

**ACCEPTANCE** - The determination of compliance with performance guarantees will be based on results of factory tests under controlled

conditions with calibrated instruments and tested per standards of the Hydraulic Institute, ISO standards, API standards, or other nationally recognized accreditation standards mutually acceptable to Company and Purchaser.

**SHIPMENT** - The term "shipment" means delivery to the initial carrier in accordance with the delivery terms of this order. Company may make partial shipments. Company shall select method of transportation and route, unless terms are f.o.b. point of shipment and Purchaser specifies the method and route and is to pay the freight costs in addition to the price. When terms are f.o.b. destination or freight allowed to destination, "destination" means common carrier delivery point (within the continental United States, excluding Alaska) nearest the destination. For movement outside the United States, company shall arrange for inland carriage to port of exit and shall cooperate with Purchaser's agents in making necessary arrangements for overseas carriage and preparing necessary documents.

**SPECIAL SHIPPING DEVICES** - On shipments to a destination in the continental United States or Canada, Company has the right to add to the invoice, as a separate item, the value of any special shipping device (barrel, reel, tarpaulin, cradle, crib and the like) used to contain or protect the product(s) invoiced, while in transit. Full credit will be given on the return to Company of the device in a reusable condition, f.o.b. destination, freight prepaid.

**DELAYS** - If Company suffers delay in performance due to any cause beyond its control, including but not limited to act of God, war, act or failure to act of government, act or omission of Purchaser, fire, flood, strike or labor troubles, sabotage, or delay in obtaining from others suitable services, materials, components, equipment or transportation, the time of performance shall be extended a period of time equal to the period of the delay and its consequences. Company will give to Purchaser notice in writing within a reasonable time after Company becomes aware of any such delay.

**NONCANCELLATION** - Purchaser may not cancel or terminate for convenience, or direct suspension of manufacture, except on mutually acceptable terms.

**STORAGE** - Any item of the product(s) on which manufacture or shipment is delayed by causes within Purchaser's control, or by causes which affect Purchaser's ability to receive the product(s), may be placed in storage by Company for Purchaser's account and risk.

**TITLE AND INSURANCE** - Title to the product(s) and risk of loss or damage shall pass to Purchaser at the f.o.b. point, except that a security interest in the product(s) and proceeds and any replacement shall remain in Company, regardless of mode of attachment to realty or other property, until the full price has been paid in cash. Purchaser agrees to do all acts necessary to perfect and maintain said security interest, and to protect Company's interest by adequately insuring the product(s) against loss or damage from any external cause with Company named as insured or co-insured.

**INSPECTIONS / EXPEDITING** - The Company wishes to clarify that it will have to restrict access to agreed upon reasonable times and only for the purpose of conducting those inspections agreed upon. We request 72 hours notice prior to each visit. We request notification prior to visits to our subcontractors and require that we accompany inspectors/expeditors on their visit(s).

**TERMS OF PAYMENT** - Unless otherwise stated all payments shall be Letter of Credit or Net Thirty (30) Days and in United States dollars, and a pro rata payment shall become due as each shipment is made. If shipment is delayed by Purchaser, date of readiness for shipment shall be deemed to be date of shipment for payment purposes. If at any time in Company's judgment Purchaser may be or may become unable or unwilling to meet the terms specified, Company may require satisfactory assurances or full or partial payment as a condition to commencing or continuing manufacture or making shipment; and may, if shipment has been made, recover the product(s) from the carrier, pending receipt of such assurances.

**TAXES** - Any applicable duties or sales, use, excise, value added or similar taxes will be added to the price and invoiced separately (unless acceptable exemption certificate is furnished).

**PRODUCT RETURN** - Products can be returned for credit only after receiving Company's authorization and shipping instructions. Consignor's name and address must be plainly written on the shipping tag.

For more information, please contact:

## Terms and Conditions (cont.)

**PATENTS** - Company shall pay costs and damages finally awarded in any suit against Purchaser or its vendees to the extent based upon a finding that the design or construction of the product(s) as furnished infringes a United States patent (except infringement occurring as a result of incorporating a design or modification at Purchaser's request) provided that Purchaser promptly notifies Company of any charge of such infringement, and Company is given the right at its expense to settle such charge and to defend or control the defense of any suit based upon such charge. **This paragraph sets forth company's exclusive liability with respect to patents.**

**BUYER DATA** - Timely performance is contingent upon the Purchaser supplying to the Company, when needed, all required technical information, including drawing approval, and all required commercial documentation.

**NUCLEAR** - Purchaser represents and warrants that the product(s) covered by this contract shall not be used in or in connection with a nuclear facility or application.

**PRICES** - The prices stated herein will remain firm for the period up to the stated date of shipment providing the shipment is not delayed by the customer. If shipment is delayed by the customer beyond the shipment date quoted herein, the prices will be based on the prices in effect at time of shipment, including storage and material handling costs. In no event shall the adjusted price be less than the original order price, including change orders. Prices are F.O.B. Shipping Point, unless otherwise specified. When price includes transportation and other charges pertaining to the shipment of goods, any increase in transportation rates and other charges will be for the account of the purchaser. There will be an extra charge for any test other than that which may be normally run by the Company, or for any test performed to suit the convenience of the purchaser.

**CONTROLLING PROVISIONS** - These terms and conditions shall control with respect to any purchase order or sale of the Company's products. No waiver, alteration or modification of these terms and conditions whether on Purchaser's purchase order or otherwise shall be valid unless the waiver, alteration or modification is specifically accepted in writing and signed by an authorized representative of the Company.

**EXPORT** - If this transaction involves export, the following additional terms and conditions shall apply:

- Compliance is required for all applicable US export laws, and the export laws of the country from where the product is exported.
- **PACKING** - when packing is in IBG scope of supply, equipment will be packed, boxed or crated in accordance with the Company's standard commercial practice, for under deck export shipment, unless otherwise agreed.
- **LETTER OF CREDIT** - Unless otherwise specified in writing, payment shall be made by irrevocable letter of credit in form acceptable to Company, confirmed by a major USA bank, acceptable to the company and providing for payment in full in United States dollars against presentation of United States inland shipping documents and invoices, such letter of credit to be established prior to company's acceptance of the order. The letter of credit shall also provide that in the event Company is, for any reason beyond its control, prevented from making shipment from Company's factory or delivery at the port of embarkation, a certificate of manufacture of the whole or any part of the goods shall constitute delivery of such whole or any part of the goods and payment in full of any and all drafts drawn against the letter of credit for the goods so "delivered" shall be made upon presentation of such certificates of manufacture in lieu of United States inland shipping documents. In the event that Company is prevented by law, or otherwise, from making shipment from Company's factory or delivery at port of embarkation of the goods or any part thereof, on completion of manufacture, Company reserved the right to place the goods in storage for the Purchaser's account and risk. Any charges incurred in this connection will be for the account of the Purchaser at cost and will be payable upon demand. In regions where Letters of Credit are not available, surety bonds will be utilized in lieu of the bank guarantee.
- **COMPANY AS AGENT** - If Company makes or arranges for ocean shipment, Company shall act as agent for the Purchaser and reserves the right to procure full insurance coverage, including war risk insurance, at the expense of the Purchaser. All expenses incurred in this connection will be payable upon demand to the Company. If Company as agent applies for or secures manufacturing, financing, exporting or other licenses required by the United States Government, or any department thereof, Company shall make such applications or secure such licenses solely as agent for the purchaser, and assumes no responsibility therefore.

**Pure-Flo Headquarters**  
33 Centerville Road  
Lancaster, PA 17603-2064 USA  
Phone +1 (800) 787-3561  
Phone +1 (717) 509-2200  
Fax +1 (800) 239-9402

Website: [www.ittpureflo.com](http://www.ittpureflo.com)  
E-mail: [pureflo.custserv@itt.com](mailto:pureflo.custserv@itt.com)

### Valve Office Locations:

Pure-Flo  
110-B West Cochran  
Simi Valley, CA 93065 USA  
Phone +1 (800) 926-8884  
Phone +1 (805) 520-7200  
Fax +1 (805) 520-7205

Pure-Flo  
Richards Street  
Kirkham, Lancashire  
PR4 2HU, England  
Phone +44-1772-682696  
Fax +44-1772-686006



© 2006 ITT Corporation  
Industrial & BioPharm Group

8H.POD